



Tubular Specialties Manufacturing, Inc.

13011 South Spring Street, Los Angeles, CA 90061-1685

Phone 800/Grab Bar (800/472-2227) or 310/515-4801

www.GrabBar.com • Fax 310/217-0653

**740-PH,
740-PHI**

Shower Seat for Roll-In Shower

Phenolic Slats

Technical Data

Revised Oct. 2008

Page One of Two



Shown in Ivory Phenolic,
Model 740-PHI

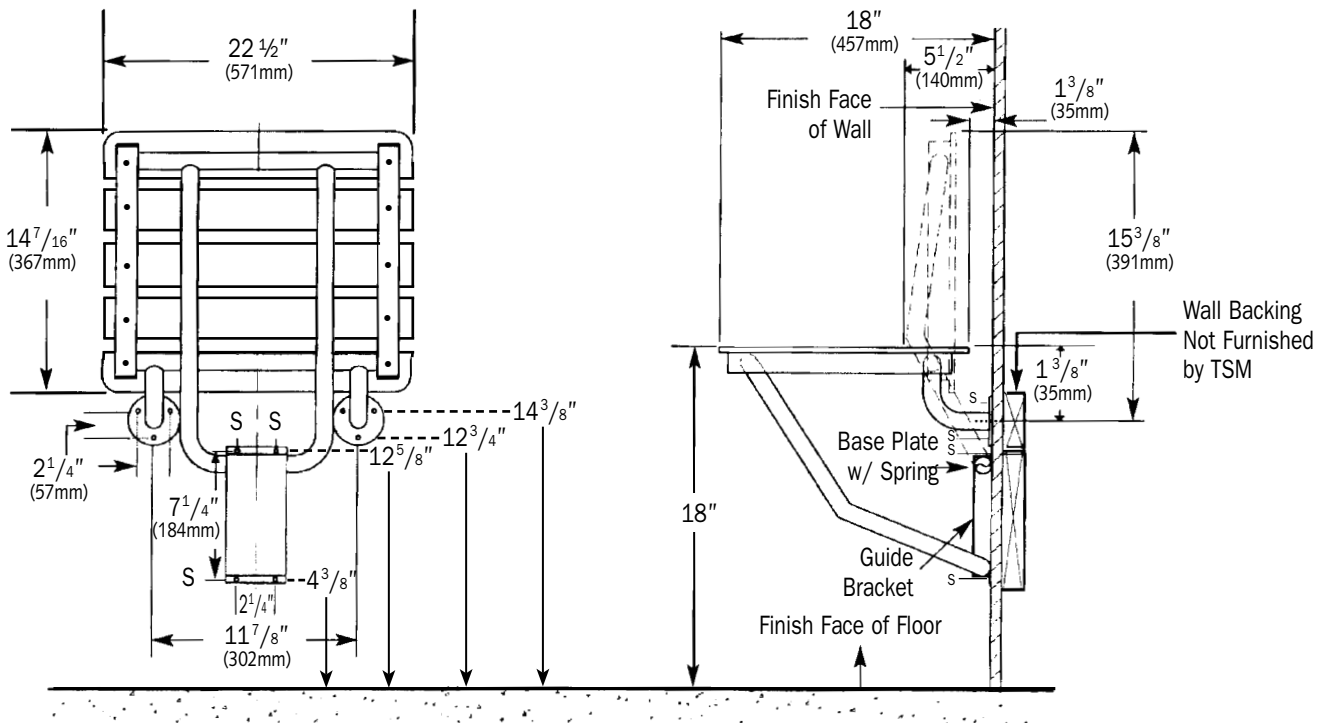

Guarantee

TSM 740-PH Shower Seat for Roll-In Shower is guaranteed against defects in workmanship and material for one year from shipping date.



Model Numbers

- 740-PH Phenolic Slats, Woodgrain
- 740-PHI Phenolic Slats, Ivory



Specification

Folding Shower Seat for Roll-In Shower shall have a frame constructed of type 304, satin finish stainless steel of 18 gauge (1.2mm) 1¼" (32mm) square tubing and 18 gauge (1.2mm) 1" (25mm) diameter seamless tubing. Shower seat shall be equipped with two 3" (76mm) diameter mounting flanges of stainless steel satin finish type 304 (18-8) 8 gauge (4.2mm) with three ¼" (6mm) mounting holes. Guide bracket shall be 16 gauge (1.6mm) stainless steel type 304 (18-8), formed construction with four ¼" mounting holes. A spring of 24 gauge (0.6mm) stainless steel type 304 (18-8) shall be spot welded

to heavy-gauge stainless steel base plate. Seat shall be four (4) phenolic slats 2¹³/₁₆" x ½" thick (71 x 13mm) in [woodgrain] [ivory]. Seat shall be able to lock in upright position when not in use. Shower seat shall comply with barrier-free accessibility guidelines (including ADAAG in U.S.A.).

Shower Seat for Roll-In Shower shall be Model [740-PH] [740-PHI] as manufactured by Tubular Specialties Manufacturing, 13011 South Spring Street, Los Angeles, California 90061, tel 800-Grab Bar.



Operation

The guide bracket supports U-shaped legs which move freely up and down, allowing user to lower the seat to sitting position or fold against the wall, and is held in place by clip with spring action. The spring at the top of the base plate holds

the seat in an upright position. When seat is pulled down, legs are released from the spring and the seat folds down into sitting position.



Installation

1. The 740-PH is manufactured to meet and exceed ADAAG requirements as published in ANSI A117.1-1986 and CFR 28 part 36, Federal Register Vol. 56 #144, July 26, 1991, section 4.21.3 and section 4.26.3 that the fabricated product shall be of adequate strength to support a load of 250 pounds (113.4kg). Having said this, the seat is only as strong as the mounting surface to which it is attached. Consult local codes to assure compliance.
2. In-wall backing is required. If the shower is prefabricated, secure and appropriate backing must be provided by the shower stall manufacturer.
3. Seat is surface mounted to wall through in-wall backing with two mounting flanges at top and guide bracket below at locations marked by an "S". While local codes must be complied with in mounting seat, the recommended seat height is 18" (457mm) above floor level. The template that is supplied with each seat will allow you to mount the seat at that height with mounting holes from finished floor at 4³/₈" & 12⁵/₈" for guide bracket and 12³/₄" & 14³/₈" for flanges.
4. The horizontal section of the U-shaped legs must be positioned in-between the base plate and cover guide bracket before seat is secured to wall.
5. It is the installer's responsibility to select fasteners that are appropriate for the wall condition and application; TSM does not include fasteners with shower or tub seats.
6. All accessories must be checked frequently to ensure that the installation is secure and the product is in good working condition.



Guarantee

TSM 740-PH Shower Seat for Roll-In Shower is guaranteed against defects in workmanship and material for one year from shipping date.