



**Tubular Specialties Manufacturing, Inc.**  
 13011 South Spring Street, Los Angeles, CA 90061-1685  
 Phone 800/Grab Bar (800/472-2227) or 310/515-4801  
 www.GrabBar.com • Fax 310/217-0653

**731-A**

**Folding Wheelchair Transfer Seat**  
 Naugahyde Cushion

**Technical Data**

Revised Oct. 2008

Page One of Two



Left Hand Shown



Right Hand Shown

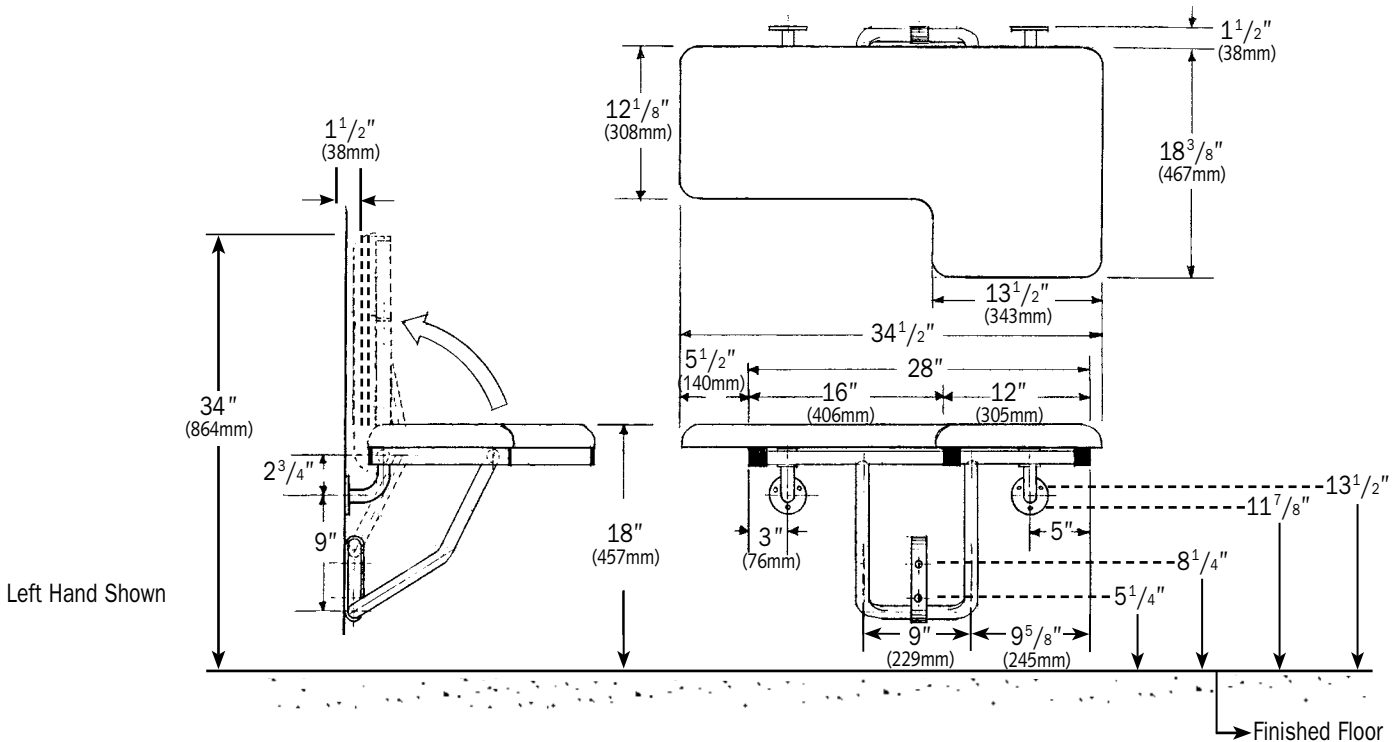

Left Hand Shown

 **Guarantee**  
 TSM 731-A Folding Wheelchair Transfer Seat is guaranteed against defects in workmanship and material for one year from shipping date.



## Specification

Folding Wheelchair Transfer Seat shall have a frame constructed of type 304, satin finish stainless steel of 18 gauge (1.2mm) 1¼" (32mm) square tubing and 18 gauge (1.2mm) 1" (25mm) diameter seamless tubing. Shower seat shall be equipped with two (2) 3" (76mm) diameter mounting flanges of stainless steel satin finish type 304 (18-8) 8 gauge (4.2mm) with three (3) ¼" (6mm) mounting holes. Guide bracket shall be 16 gauge (1.6mm) stainless steel type 304 (18-8), formed construction with two (2) ¼" mounting holes. Seat shall be naugahyde white

cushion covering 2½" (64mm) thick foam rubber. Seat shall be able to lock in upright position when not in use. Handing shall be [right] [left]. Shower seat shall comply with barrier-free accessibility guidelines, including ADAAG in U.S.A.

**Folding Wheelchair Transfer Seat shall be Model 731-A as manufactured by Tubular Specialties Manufacturing, 13011 South Spring Street, Los Angeles, California 90061, tel 800-Grab Bar.**



## Operation

The guide bracket supports U-shaped legs which move up and down with minimal but intended resistance, allowing the seat to be lowered into position or raised to be folded parallel to the wall. TSM's unique counterbalance mechanism prevents accidental freefall of the seat when it is lowered into position or raised to be folded up against the wall.

The Folding Wheelchair Transfer Seat complies with the Americans with Disabilities Act (ADA) for use in a 36" x 36" shower stall. The seat's distinctive shape allows the user to transfer from a wheelchair to the narrow part of the seat and slide across to the wide section which is installed at the corner of the stall. Grab bars should be specified in conjunction with all shower seats.



## Installation

1. The 731-A is manufactured to meet and exceed ADAAG requirements as published in ANSI A117.1-1986 and CFR 28 part 36, Federal Register Vol. 56 #144, July 26, 1991, section 4.21.3 and section 4.26.3 that the fabricated product shall be of adequate strength to support a load of 250 pounds (113.4kg). Having said this, the seat is only as strong as the mounting surface to which it is attached. Consult local codes to assure compliance.
2. In-wall backing is required. If the shower is prefabricated, secure and appropriate backing must be provided by the shower stall manufacturer.
3. Seat is surface mounted to wall through in-wall backing with two mounting flanges at top and guide bracket below. While local codes must be complied with in mounting seat, the recommended seat height is 18" (457mm) above floor level. The template that is supplied with each seat will allow you to mount the seat at that height with mounting holes from finished floor at 5¼" & 8¼" for guide bracket and 11-7/8" & 13½" for flanges.
4. It is the installer's responsibility to select fasteners that are appropriate for the wall condition and application; TSM does not include fasteners with shower or tub seats.
5. All accessories must be checked frequently to ensure that the installation is secure and the product is in good working condition.



### Guarantee

TSM 731-A Wheelchair Transfer Seat is guaranteed against defects in workmanship and material for one year from shipping date.