



Tubular Specialties Manufacturing, Inc.

13011 South Spring Street, Los Angeles, CA 90061-1685

Phone 800/Grab Bar (800/472-2227) or 310/515-4801

www.GrabBar.com • Fax 310/217-0653

5352

Technical Data

Revised Jan. 2007

Countertop Mounted Waste Receptacle

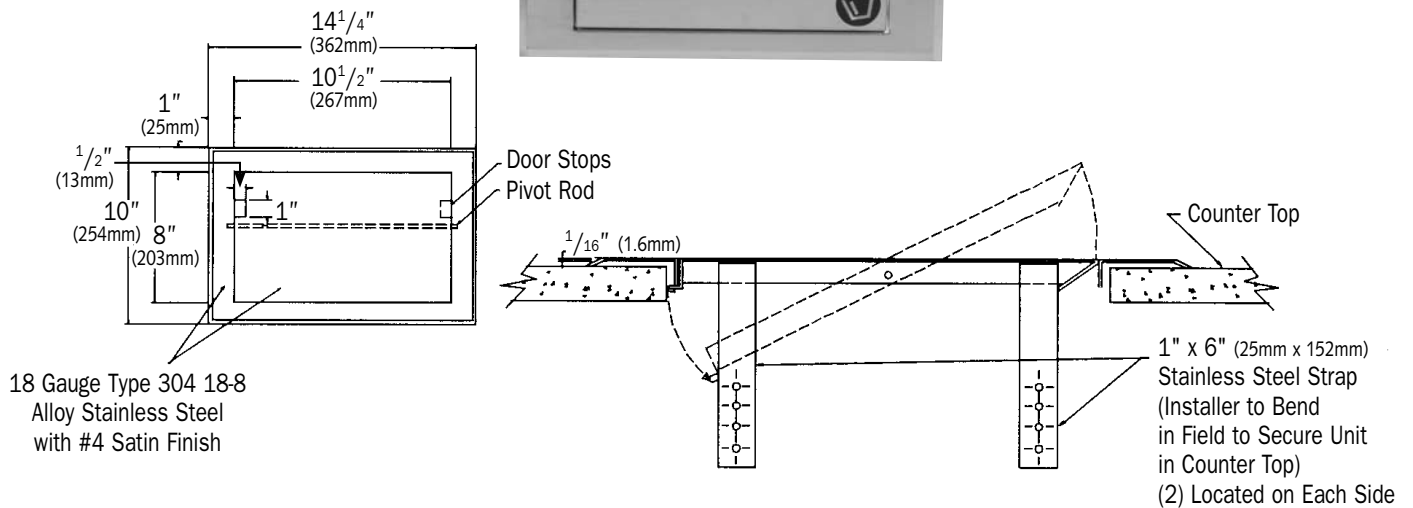
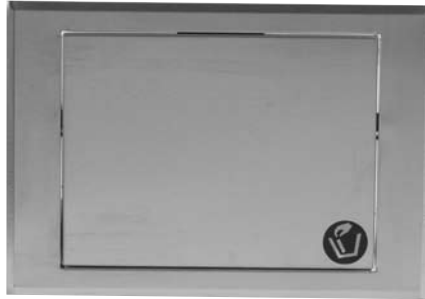

18 Gauge Type 304 18-8 Alloy Stainless Steel with #4 Satin Finish



Specification

Countertop Mounted Waste Receptacle shall receive 1 cu. ft. (0.3m³) or 7.5 gal. (28 liters) of solid waste into loose waste can. Door and face trim shall be fabricated of alloy 18-8 type 304 stainless steel, 18 gauge. All exposed surfaces shall have #4 satin finish and shall be protected during shipment with PVC film easily removable after installation. Face trim shall be one-piece construction with no miters or welding. Adjustable stainless steel mounting straps shall accommodate counter thickness from 1/2" to 4" (13mm to 102mm) thick. Waste receptacle shall be

provided loose and shall be all-welded construction fabricated of corrosion-protected steel, 22 gauge, 12" x 12" x 12" (305mm). Downward finger pressure shall open pivoting waste door for disposal of used paper towels into waste receptacle. Waste door shall return to closed position when pressure is removed.

Countertop Mounted Waste Receptacle shall be Model 5352 as manufactured by Tubular Specialties Manufacturing, 13011 South Spring Street, Los Angeles, California 90061, tel 800-Grab Bar.



Operation

Waste is inserted through the swinging door by downward pressure. When pressure is released, the waste door returns to

its closed position. Waste can is manually emptied on a cycle determined by maintenance needs.



Installation

1. Countertop opening required is 8³/₄" H x 12¹/₂" W.
2. Position unit into appropriate countertop cutout (by others).
3. Installer to bend mounting straps upward to suit countertop thickness. Secure mounting straps to underside of

countertop with mounting screws (supplied). Note: Receptacle is situated on vanity bottom directly below waste door.

4. All accessories should be inspected periodically to make sure their attachment is not loosening.



TSM 5352 Countertop Mounted Waste Receptacle is guaranteed against defects in workmanship and material for one year from shipping date.