



Since 1966

## Tubular Specialties Manufacturing, Inc.

13011 South Spring Street, Los Angeles, CA 90061-1685  
Phone 800/CALL TSM (800/225-5876) or 310/515-4801  
online www.calltsm.com • Fax 310/217-0653

# 5110

## Recessed Napkin/Tampon Vendor

### Technical Data

Revised June 2001

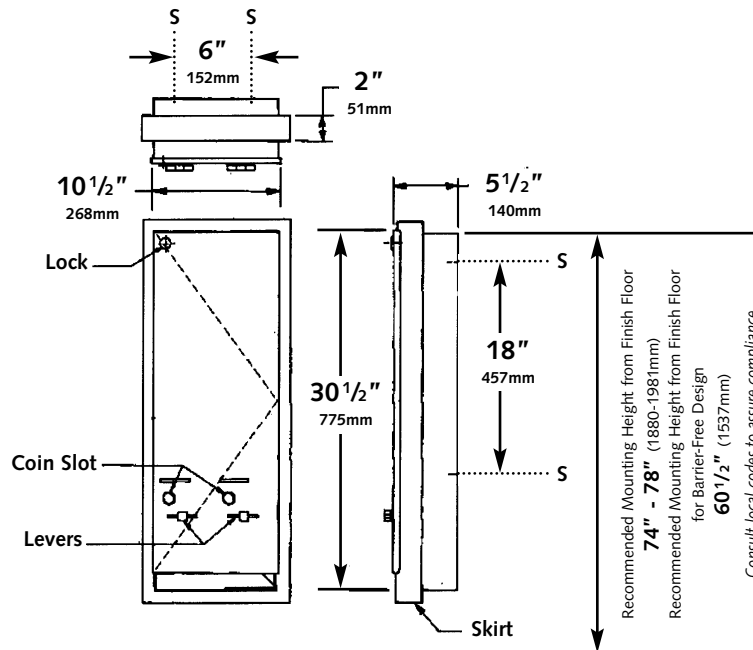

### Suggested Architectural Specification

TSM Model 5110 Recessed Napkin/Tampon Vendor from Tubular Specialties Manufacturing, Inc., Los Angeles, California, 310/515-4801 or 800/Call TSM (800/225-5876). Dispenser and Flange: Stainless steel type 304 (18-8) 22 gauge (0.8mm) satin finish, welded with no exposed fastening devices or spot welded seams.

Flange returns 1/4" (6mm) to finished wall with no face miters. Door: Stainless steel type 304 (18-8) 18 gauge (1.2mm) satin finish, mounted with heavy-duty stainless piano hinge and provided with two (2) tumbler locks. Coin operation: Coin box has tumbler lock keyed differently from dispenser door. Two (2) dispensing mechanisms are furnished for 25¢ operation. Capacity: 30 Napkins and 27 tampons.



### Operation

Insert coin in napkin or tampon mechanism and turn handle to dispense boxed sanitary napkin or tampon tube.



### Materials/Workmanship

- Cabinet** Stainless steel type 304 (18-8) 22 gauge satin finish (0.8mm), welded construction. Capacity: 30 napkins @ 4 1/4" x 3" x 1 1/8" (108x76x29mm) and 27 tampons @ 5" cylinder (127mm).
- Flange** Stainless steel type 304 (18-8) 22 gauge satin finish. Adjustable.
- Door** Stainless steel type 304 (18-8) 18 gauge satin finish (1.2mm). Secured to cabinet with full-length stainless steel piano hinge. Two (2) pin tumbler locks.
- Coin Mechanism** Single coin mechanism for 25¢ operation.



### Installation

- Recommended mounting height from finish floor to top of vendor is 74" - 78" (1880-1981mm) standard and 60 1/2" (1537mm) for barrier-free design. Consult local codes to assure compliance.
- Provide framed rough wall opening 12 1/2" wide x 26 5/8" high (318x676mm) x with a depth from 1" - 6" (25-152mm).
- Position unit to avoid pipes, vents and conduits previously installed in wall.
- After installing shims as required to give a solid base, complete installation using screws provided by manufacturer at locations marked by an "S".

Manufacturer reserves the right to alter design or dimensions without formal notice and without incurring obligation.



### Guarantee

TSM 5110 Recessed Napkin/Tampon Vendor is guaranteed against defects in workmanship and material for one year from shipping date.